

QLAS-100-15000-45-22

0.1~15GHz, 45dB, 2.2dB

Features:

- * Broad Band
- * Low Noise

Applications:

- * Wireless
- * Receiver
- * Laboratory Test
- * Radar

Electrical

Frequency:	0.1~15GHz
Gain:	45dB typ.
Gain Flatness:	±2.5dB typ.
Output Power (P1dB):	+5dBm typ.
Noise Figure:	2.2dB typ.
Spurious:	-60dBc max.
VSWR:	1.5 typ.
Voltage:	+220V AC
Impedance:	50Ω

Mechanical

Size*1: 136*186*52mm
5.354*7.323*2.047in

RF Connectors: SMA Female

[1] Exclude connectors, rack mount brackets, handles.

How To Order

[QLAS-100-15000-45-22](#)

Customization is available upon request.

Environmental

Operating Temperature:	-20~+50°C
Non-operating Temperature:	-40~+85°C

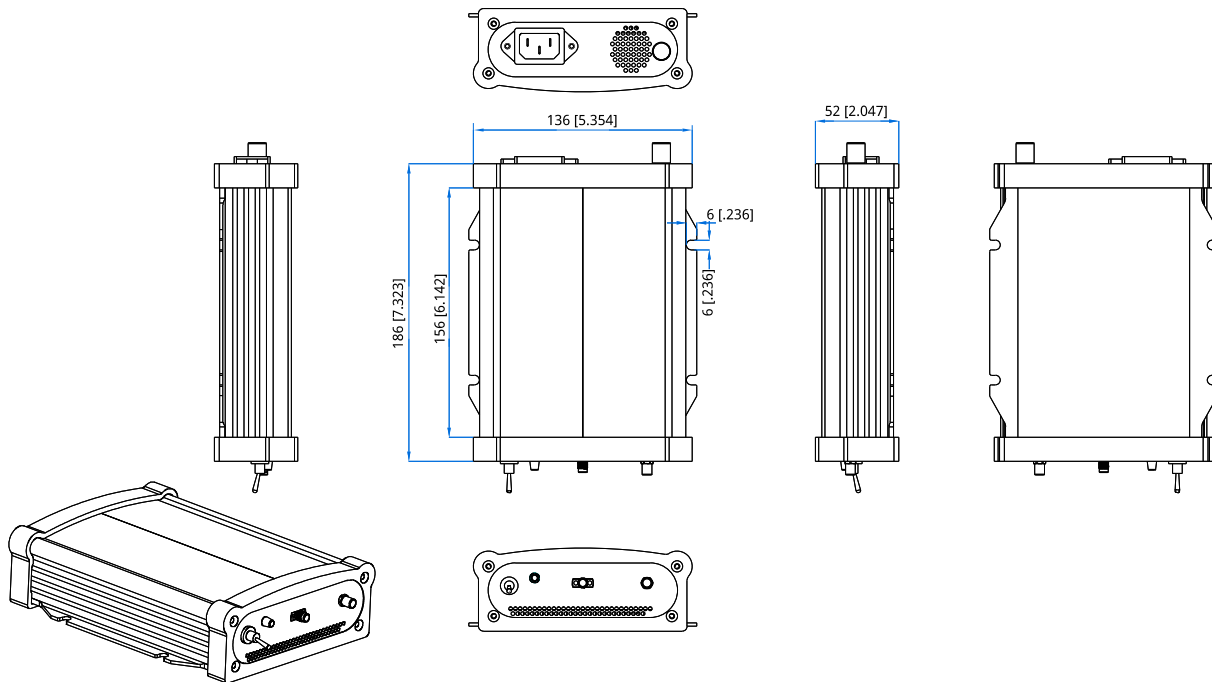
Outline Drawings

Unit: mm [in]

Tolerance: ±0.2mm [±0.008in]